



Watching Video

Concrete Pumps / Boom Pumps

# ECP63CS-5

5 ZR-  
63  
58.3  
45.6  
125  
370°  
( )



# FFH SYSTEM (Free Flow Hydraulic - )

Hawe, FFH Rexroth Everdigm

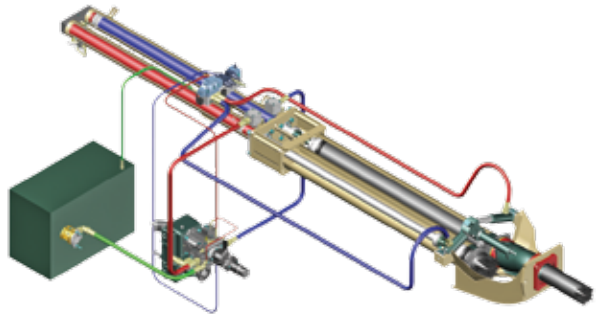

---



---



---



---



---

5 RZ-

(2 )

(1 )

(3 )

125

---



---

600

180

S2018 S- ( 200-180 )

( 180-150 )

(150-125 )

---



---



---



---



---



---



---



---

( 40 )

---



---



---



---



---



---



---



---

(OSS)

---



---



---



---



---



---

\*

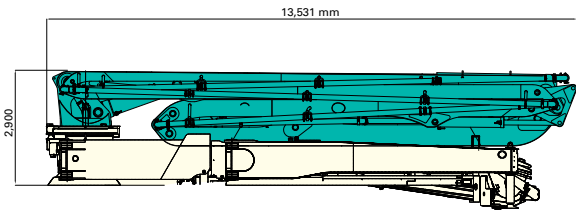

42,600kg  
700L

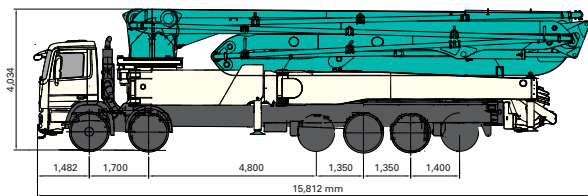

15,600kg  
41,700kg

\*

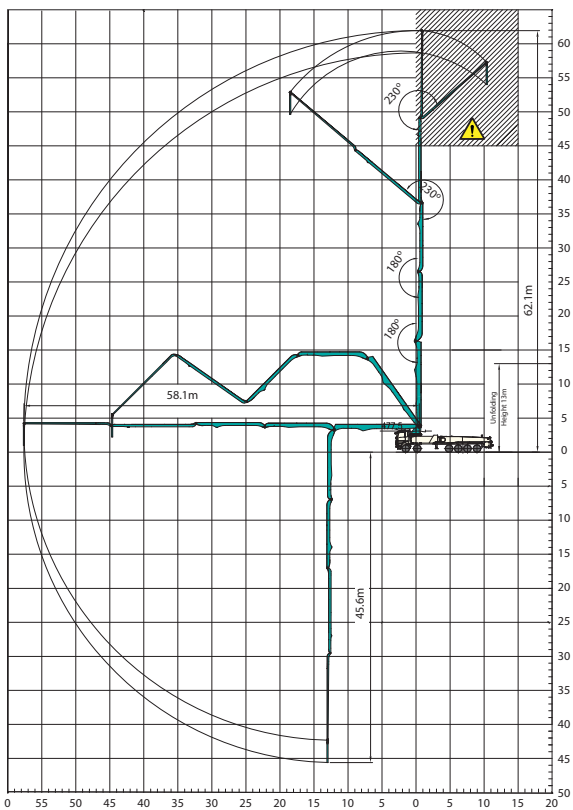

2516
A4VG125X2
( ) 230
2,500
( ) 140
2,500
( 3/ ) 160
( ) 85
( ) 25
S- S2018 200-180
( ) 600

5 RZ-
370°
63
58.3
45.6 ( 3 )
13
3
125

( 2 )
( 11 )
( 1 )
( 14.5 )

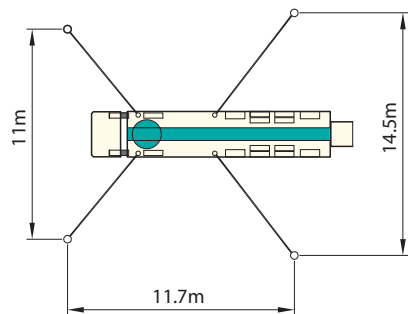

# EVERDIGM

EVERDIGM -

EVERDIGM

EVERDIGM

EVERDIGM

EVERDIGM

80

21 63



( )

( )

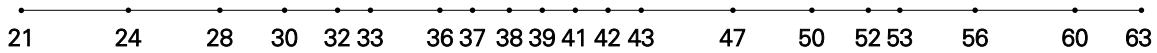

( ) ( )

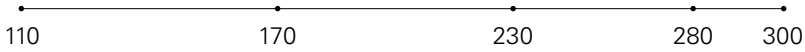

( ) ( )



( ) ( )

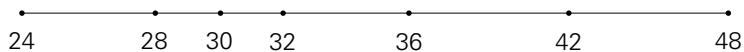

Distributed by



∴ +38(0472) 73-11-53  
∴ +38(096) 097-99-89

**Head Office & Factory**  
49, Buyeong-gil, Jincheon-eup, Jincheon-gun,  
Chungcheongbuk-do  
Tel\_+82-43-530-3300 Fax\_+82-43-530-3429

**Sales & Marketing Office**  
Room #1203, Woolim Lion's Valley 2, 2 Gasan digital 1-ro,  
Geumcheon-gu, Seoul Korea  
Tel\_+82-2-801-0800 Fax\_+82-2-801-0899

@EVERDIGM Corp. Printed in Korea

